

WAFERLOCK

Security ∞ Simplicity

L730 COMPACT HANDLE LOCK

Installation Guide

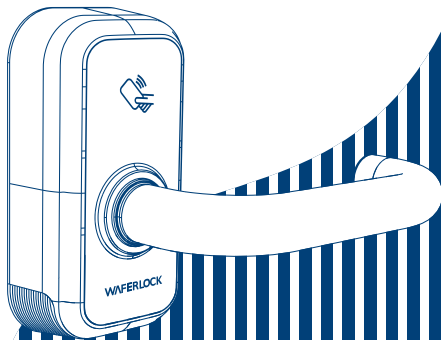

www.waferlock.com

Parts List

■ Outer Handle Set X 1

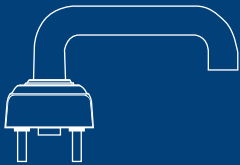

■ Inner Handle Set X 1



■ Lever Rose X 1



■ Fixing Screws X 2



■ Fixing Screws X 2



■ Spindle X 1



■ Hexagon Driver (#1.5) X 1

Hexagon Driver (#3.0) X 1

■ CR2 Lithium Battery X 1 (3V)



Battery Replacement

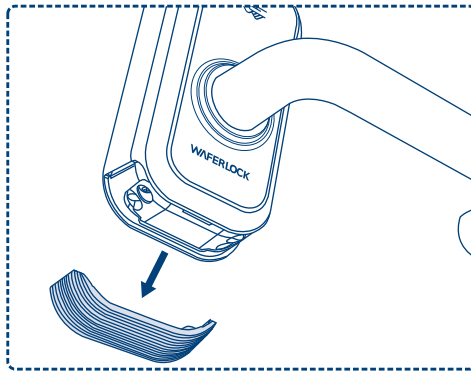

1 Remove the outer battery cover.

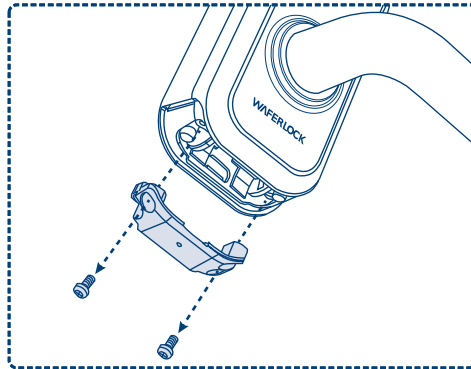

2 Remove two screws and inner battery cover.

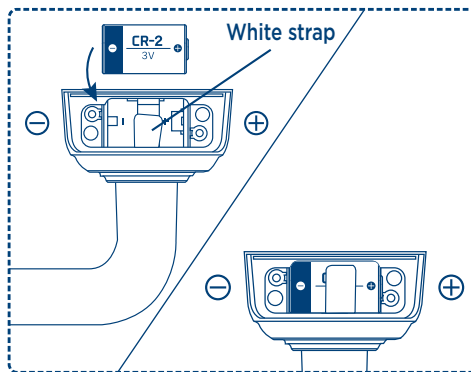

3 Insert CR2 battery and make sure the white battery strap is properly under/cross the battery. (It helps you remove the battery easily).

You will see the green and red lights alternately flashing 2 times.

If you do not see the light, please check battery polarity (+/-) and try again.

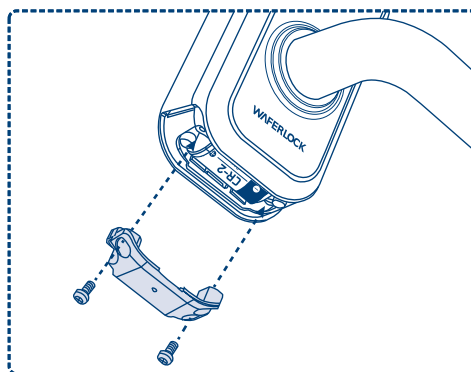

4 Attach the inner battery cover and tighten the two screws fully.

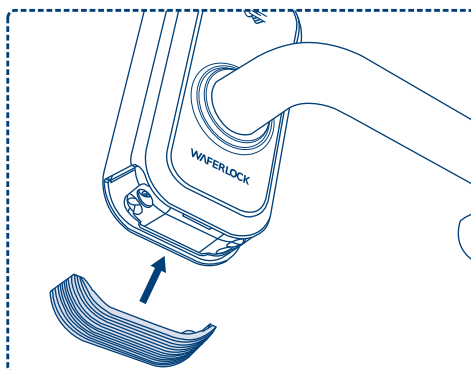

5 Attach the outer battery cover properly.

© L730 Installation Diagram

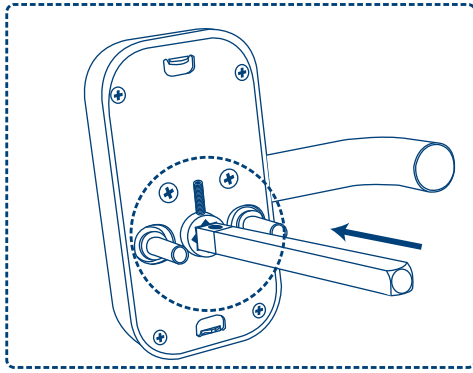

- 1 Make sure the spindle is pushed all the way into the lever with right position. Then, tighten the fixing screws in place.

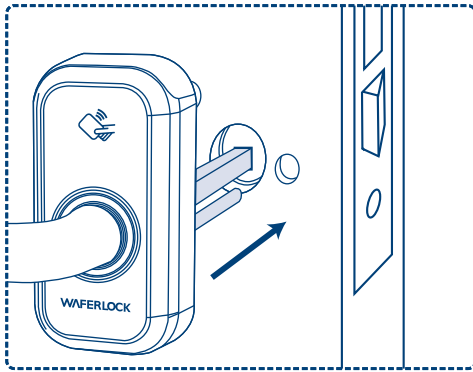

- 2 Push the stud and spindle through the door.

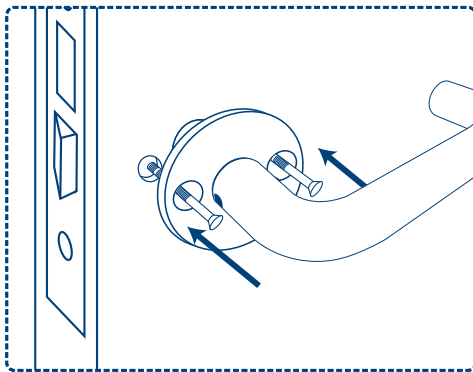

- 3 Mount the inner handle set and tighten all fixing screws fully.

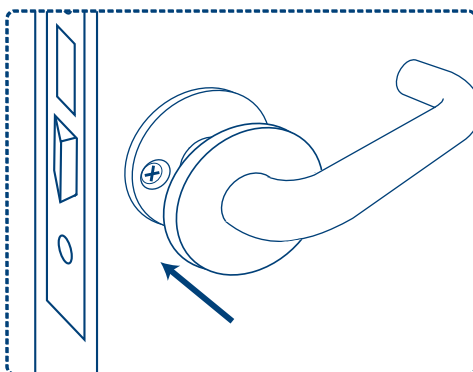

- 4 Attach the lever rose properly.

■ Your Warranty

Your Warranty covers all manufacturers' defects in workmanship and material. It does not cover any unit that is damaged beyond normal usage, by improper installations, by contacts to chemicals, or any other acts or omissions unsanctioned within the user manual.

All components are covered for 1 year after the date of purchase or installation from supplier.

The user is required to provide dated proof of purchase. WAFERLOCK or its authorized distributors will determine if there is a warrantable condition associated with material and/or manufacturing workmanship. If the lock conforms to the warranty conditions, the lock will be repaired free of charge. The shipping freights would be at owner's expense.

The warranty does not include any further obligation whatsoever, including but not limited to the installation of the replacement unit to the customer's lock. All other warranties, express or implied, are disclaimed. All collateral agreements, which purport to modify this limited warranty, are of no effect.

■ CE Marking

This device has been tested to and conforms to the regulatory requirements of the European Union and has attained CE Marking. The CE Mark is a conformity marking consisting of the letters "CE". The CE Mark applies to products regulated by certain European health, safety and environmental protection legislation. The CE Mark is obligatory for products it applies to: the manufacturer affixes the marking in order to be allowed to sell his product in the European market.

This product conforms to the essential requirements of the RED directive 2014/53/EU in order to attain CE Marking.

The CE Marking is not a quality mark. Foremost, it refers to the safety rather than to the quality of a product. Secondly, CE Marking is mandatory for the product it applies to, whereas most quality markings are voluntary.

WAFERLOCK CORPORATION

Tel: 886-4-24620208 Fax: 886-4-24636286
No.16 Ke-Yuan 2nd Rd., Central Taiwan Science Park
Taichung City 407, Taiwan
E-mail: info@waferlock.com